

COUNTER TOP CONSTRUCTION

- 16 GA. ST/STL
- TYPE 304 3/ #4 FINISH
- REINFORCED WITH 20 GA. PAINT LOCK STEEL HAT SECTIONS
- UNDERSIDE SOUND DEADENED

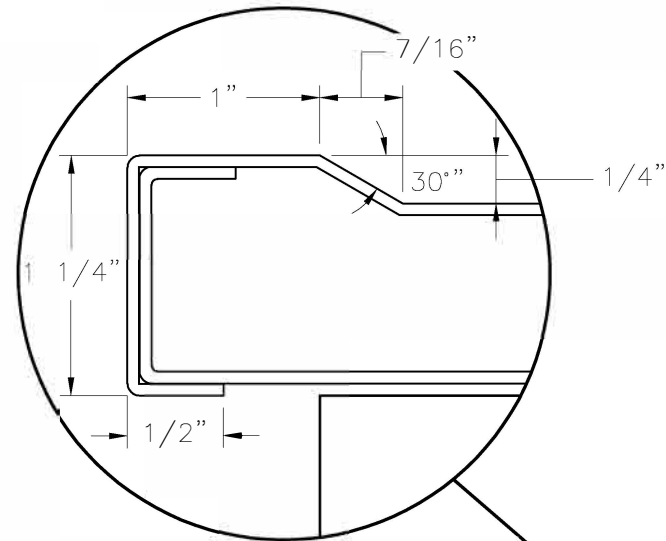

ENLARGED MARINE EDGE DETAIL

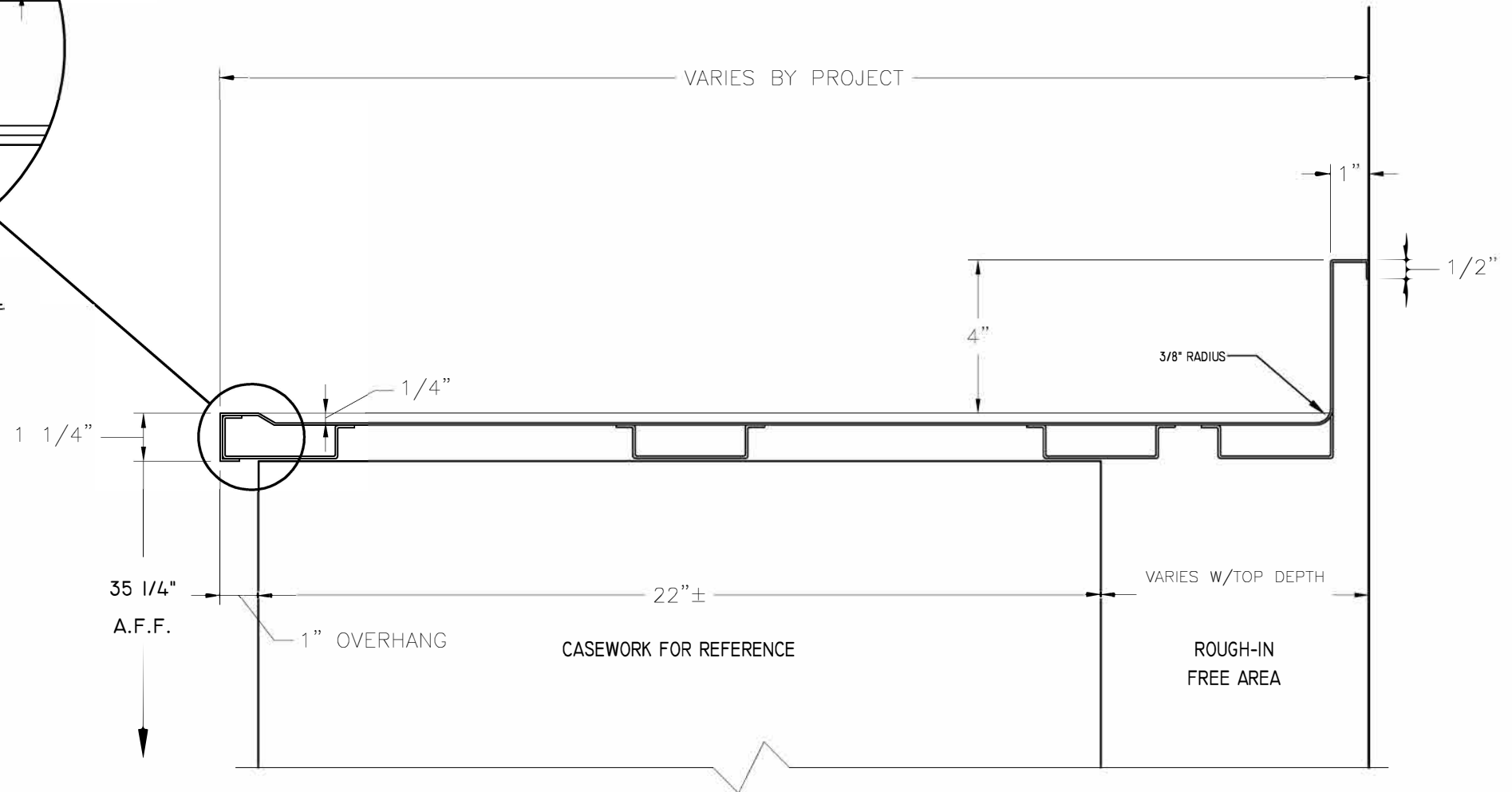

**1** TYPICAL PERIMETER STAINLESS STEEL COUNTER TOP WITH MARINE EDGE AND HAT CHANNEL SUPPORT

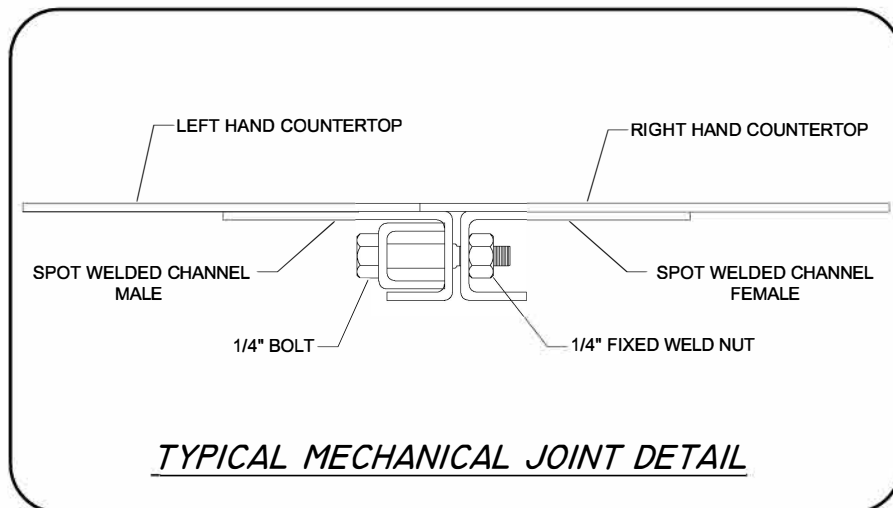

TYPICAL MECHANICAL JOINT DETAIL

NOTES:

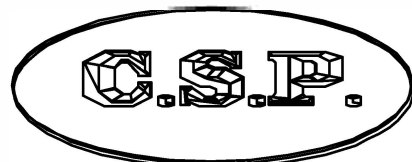

CUSTOM STAINLESS PRODUCTS INC.  
24 VULCAN STREET  
TORONTO, ON M9W 1L2  
TEL: (416) 240 0669  
FAX: (416) 240 8672  
RPRUKNER@CUSTOMSTAINLESSPRODUCTS.COM

CSP PROJECT NUMBER:

REVISIONS			PROJECT / TITLE	
No	DATE	DESCRIPTION	TYPICAL DETAIL PERIMETER COUNTERTOP STANDARD DETAIL	
1	10/06/20	ADDED SHEETS 07 & 08		
2	12/30/20	REORDERED/HAT CHANNEL ADJUSTMENT		
			DRAWN BY: CADR	DATE: 07/08/16
			SCALE: 3"=1'-0"	DWG: 01

**COUNTER TOP CONSTRUCTION**

- 16 GA. ST/STL
- TYPE 304 3/ #4 FINISH
- REINFORCED WITH 20 GA. PAINT LOCK STEEL HAT SECTIONS
- UNDERSIDE SOUND DEADENED

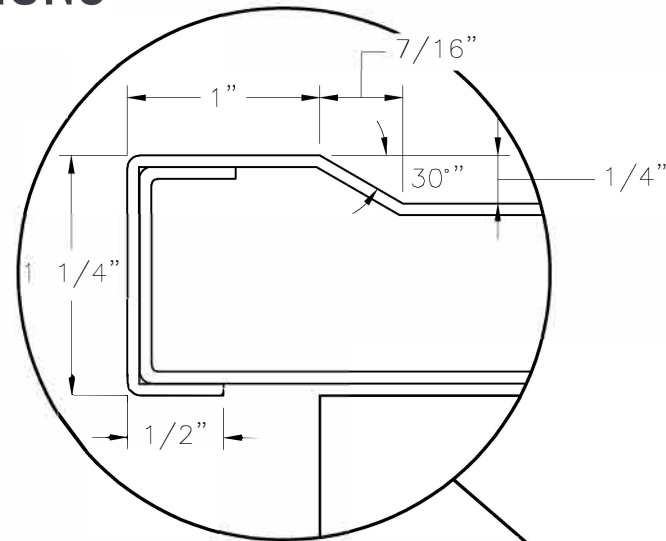

ENLARGED MARINE EDGE DETAIL

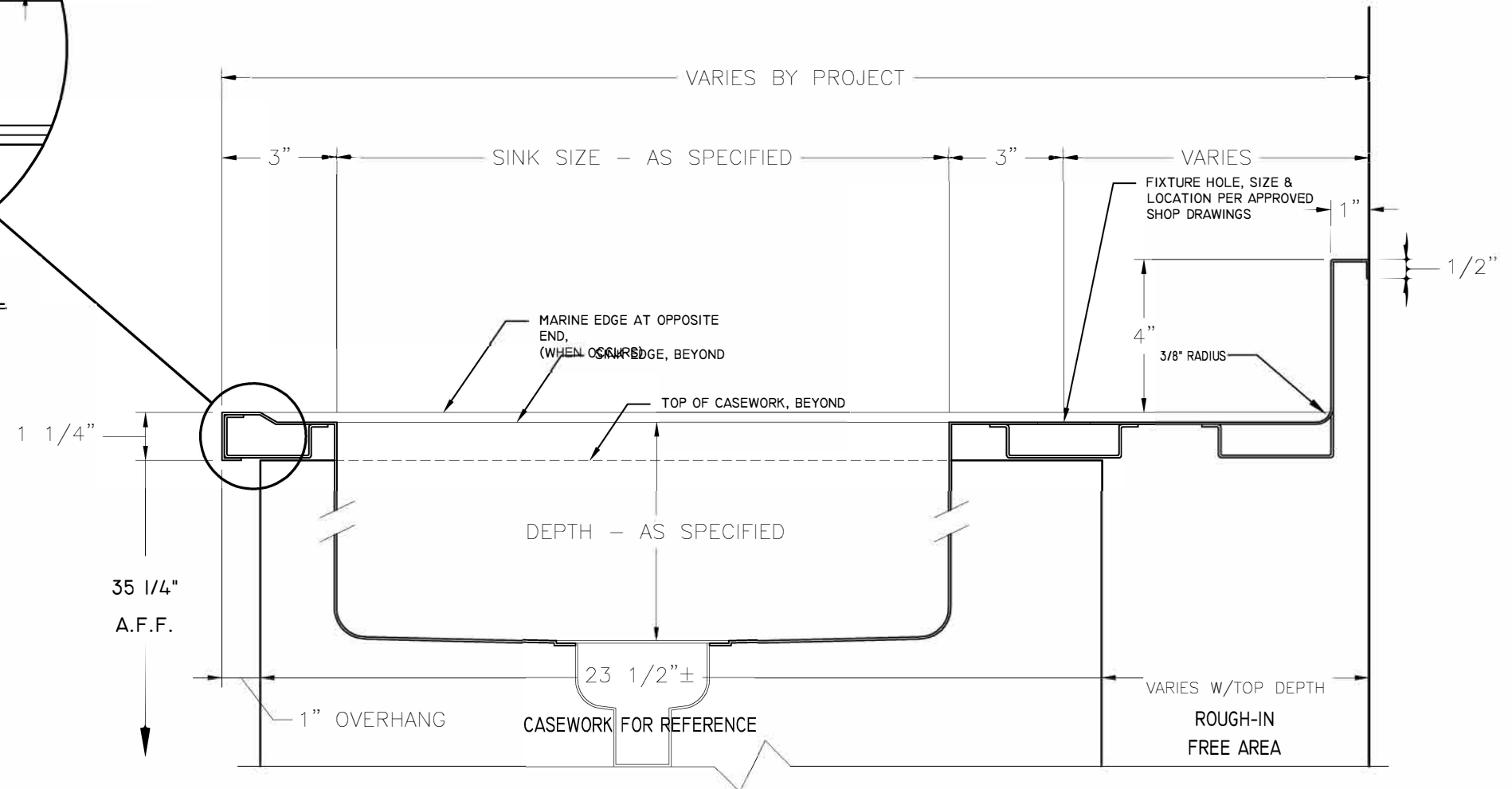

1 TYPICAL PERIMETER STAINLESS STEEL COUNTER TOP WITH MARINE EDGE, HAT CHANNEL SUPPORT, AND SINK

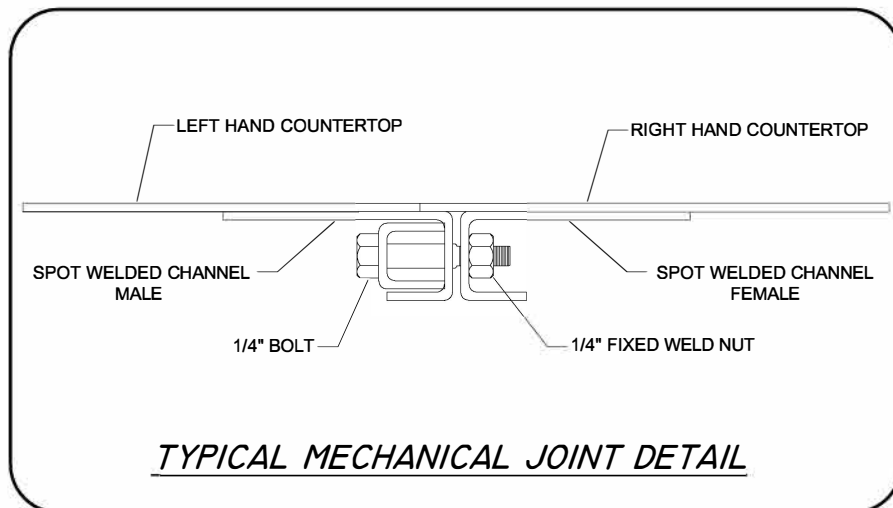

TYPICAL MECHANICAL JOINT DETAIL

NOTES:

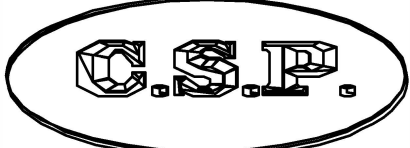

CUSTOM STAINLESS PRODUCTS INC.  
 24 VULCAN STREET  
 TORONTO, ON M9W 1L2  
 TEL: (416) 240 0669  
 FAX: (416) 240 8672  
 RPRUKNER@CUSTOMSTAINLESSPRODUCTS.COM

CSP PROJECT NUMBER:

REVISIONS		
No	DATE	DESCRIPTION
1	10/06/20	ADDED SHEETS 07 & 08
2	12/30/20	REORDERED/HAT CHANNEL ADJUSTMENT

PROJECT / TITLE	
TYPICAL DETAIL PERIMETER COUNTERTOP STANDARD DETAIL	
DRAWN BY: CADR	DATE: 07/08/16
SCALE: 3"=1'-0"	DWG: 02

**COUNTER TOP CONSTRUCTION**

- 16 GA. ST/STL
- TYPE 304 3/ #4 FINISH
- REINFORCED WITH 20 GA. PAINT LOCK STEEL HAT SECTIONS
- UNDERSIDE SOUND DEADENED

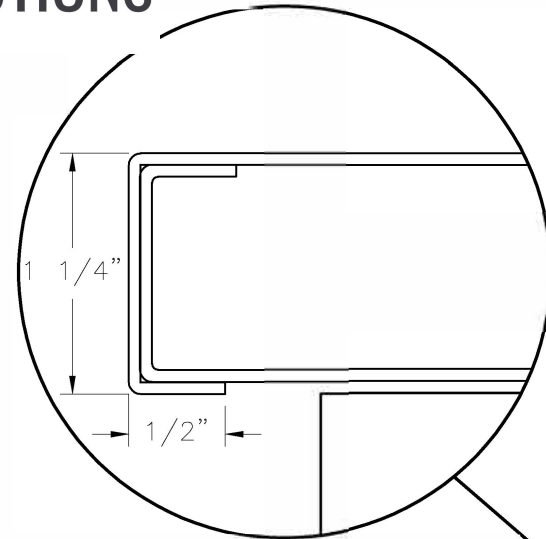

ENLARGED FRONT EDGE DETAIL

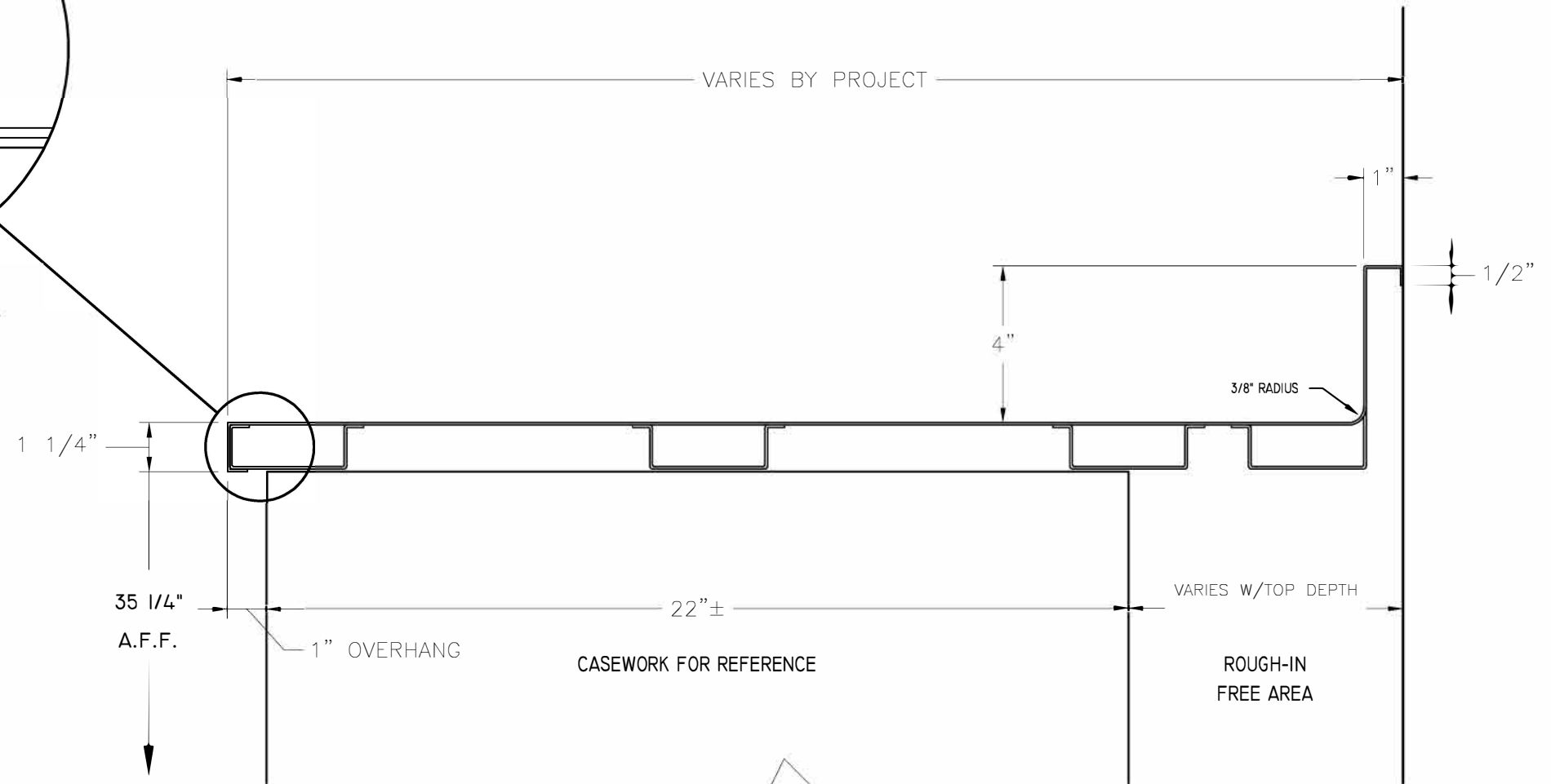

1 TYPICAL PERIMETER STAINLESS STEEL COUNTER TOP SQUARE EDGE WITH HAT CHANNEL

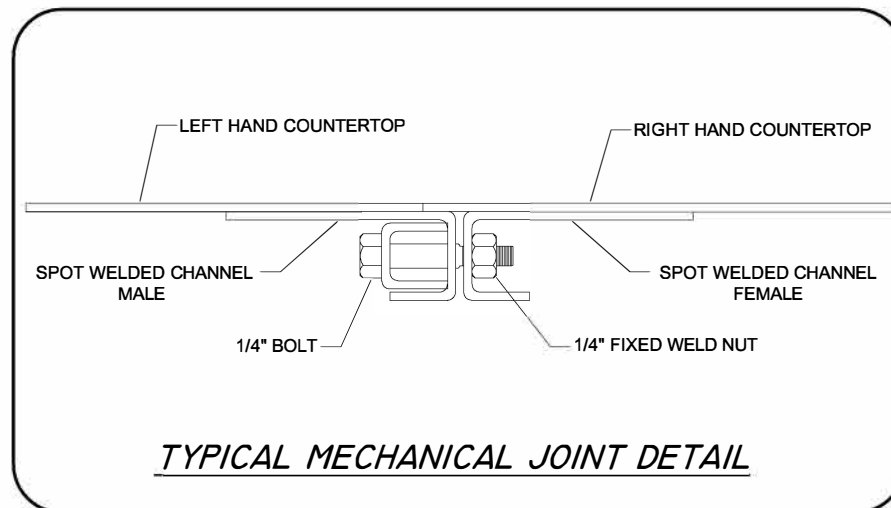

TYPICAL MECHANICAL JOINT DETAIL

NOTES:

REVISIONS		
No	DATE	DESCRIPTION
1	10/06/20	ADDED SHEETS 07 & 08
2	12/30/20	REORDERED/HAT CHANNEL ADJUSTMENT

PROJECT / TITLE	
TYPICAL DETAIL PERIMETER COUNTERTOP STANDARD DETAIL	
DRAWN BY: CADR	DATE: 07/08/16
SCALE: 3"=1'-0"	DWG: 03

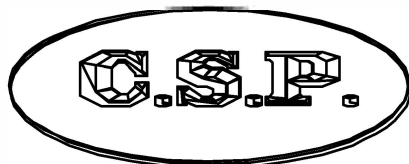

CUSTOM STAINLESS PRODUCTS INC.  
24 VULCAN STREET  
TORONTO, ON M9W 1L2  
TEL: (416) 240 0669  
FAX: (416) 240 8672  
RPRUKNER@CUSTOMSTAINLESSPRODUCTS.COM

CSP PROJECT NUMBER:

**COUNTER TOP CONSTRUCTION**

- 16 GA. ST/STL
- TYPE 304 3/ #4 FINISH
- REINFORCED WITH 20 GA. PAINT LOCK STEEL HAT SECTIONS
- UNDERSIDE SOUND DEADENED

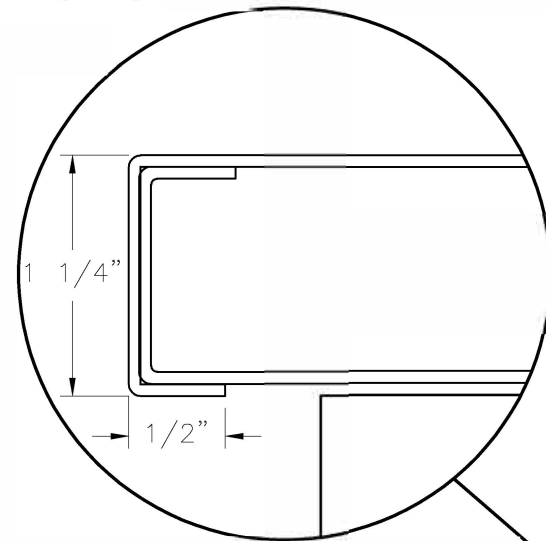

ENLARGED FRONT EDGE DETAIL

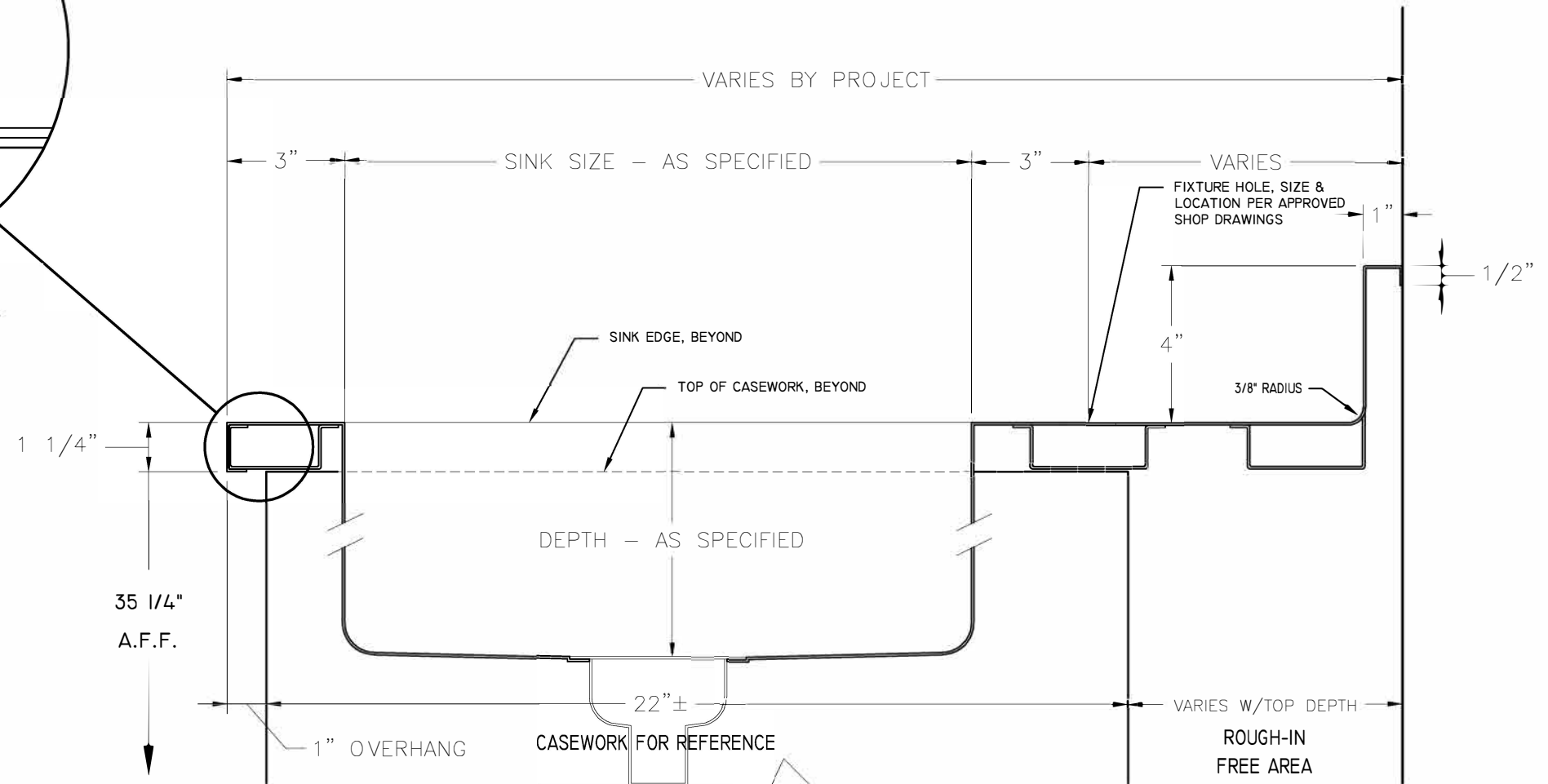

1 TYPICAL PERIMETER STAINLESS STEEL COUNTER TOP SQUARE EDGE WITH HAT CHANNEL AND SINK

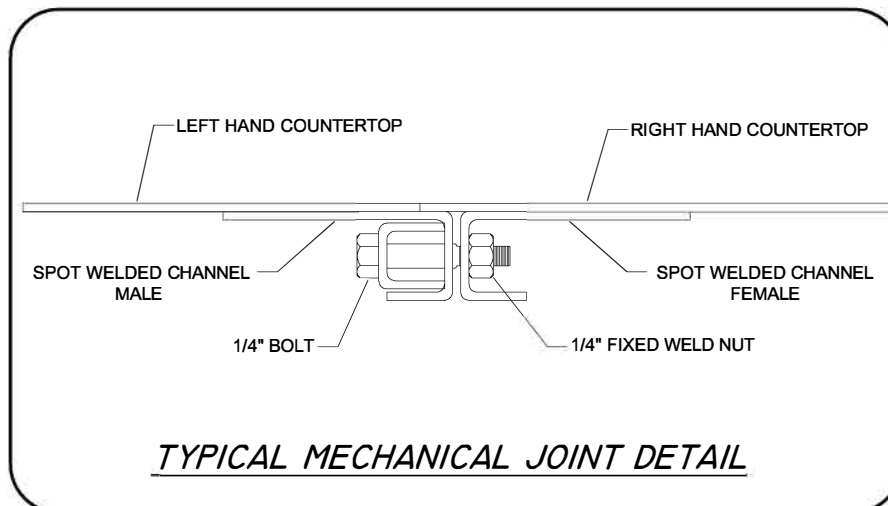

TYPICAL MECHANICAL JOINT DETAIL

NOTES:

Blank area for notes.

REVISIONS		
No	DATE	DESCRIPTION
1	10/06/20	ADDED SHEETS 07 & 08
2	12/30/20	REORDERED/HAT CHANNEL ADJUSTMENT

PROJECT / TITLE	
TYPICAL DETAIL PERIMETER COUNTERTOP STANDARD DETAIL	
DRAWN BY: CADR	DATE: 07/08/16
SCALE: 3"=1'-0"	DWG: 04

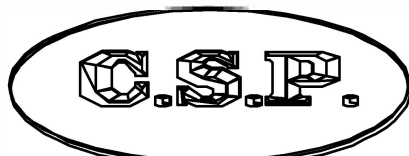

**COUNTER TOP CONSTRUCTION**

- 16 GA. ST/STL
- TYPE 304 3/ #4 FINISH
- 11/16" PLYWOOD CORE WITH 1/4" BUILD-UP STRIPS AS REQUIRED

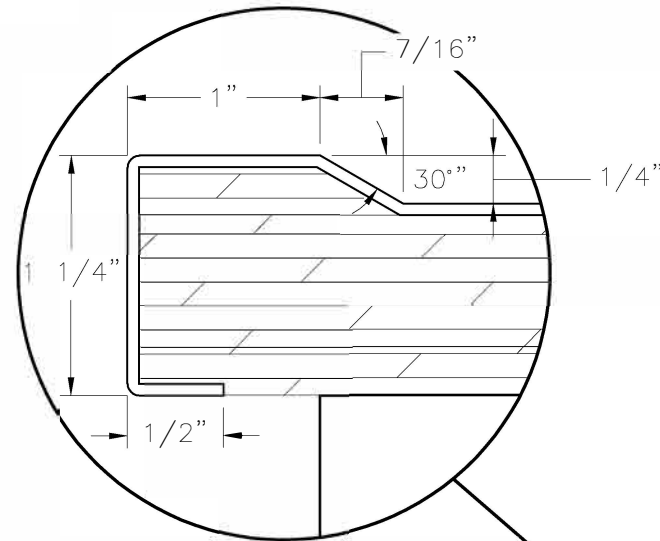

ENLARGED MARINE EDGE DETAIL

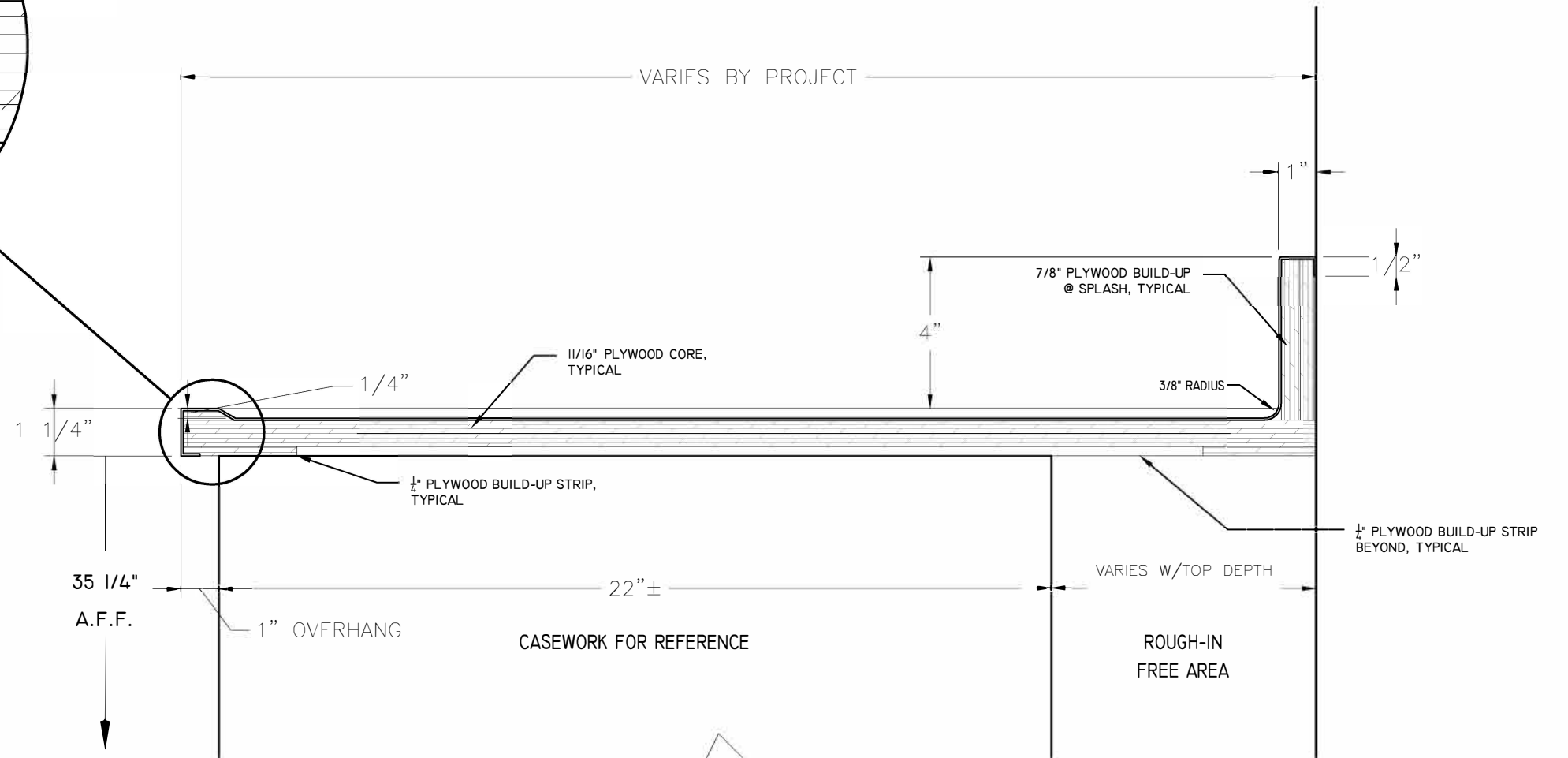

1 TYPICAL PERIMETER STAINLESS STEEL COUNTER TOP WITH MARINE EDGE AND PLYWOOD CORE

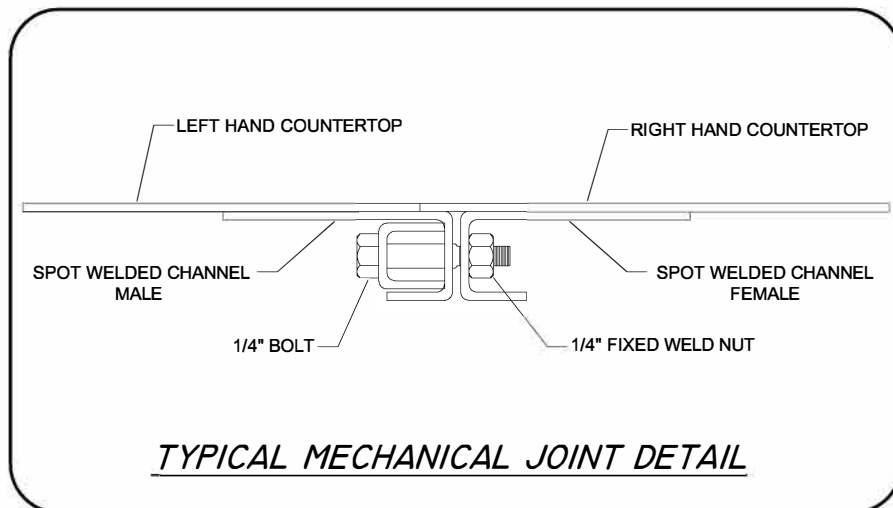

TYPICAL MECHANICAL JOINT DETAIL

NOTES:

REVISIONS		
No	DATE	DESCRIPTION
1	10/06/20	ADDED SHEETS 07 & 08
2	12/30/20	REORDERED/HAT CHANNEL ADJUSTMENT

PROJECT / TITLE	
TYPICAL DETAIL PERIMETER COUNTERTOP STANDARD DETAIL	
DRAWN BY: CADR	DATE: 07/08/16
SCALE: 3"=1'-0"	DWG: 05

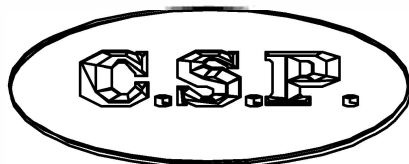

CUSTOM STAINLESS PRODUCTS INC.  
24 VULCAN STREET  
TORONTO, ON M9W 1L2  
TEL: (416) 240 0669  
FAX: (416) 240 8672  
RPRUKNER@CUSTOMSTAINLESSPRODUCTS.COM

CSP PROJECT NUMBER:

**COUNTER TOP CONSTRUCTION**

- 16 GA. ST/STL
- TYPE 304 3/ #4 FINISH
- 11/16" PLYWOOD CORE WITH 1/4" BUILD-UP STRIPS AS REQUIRED

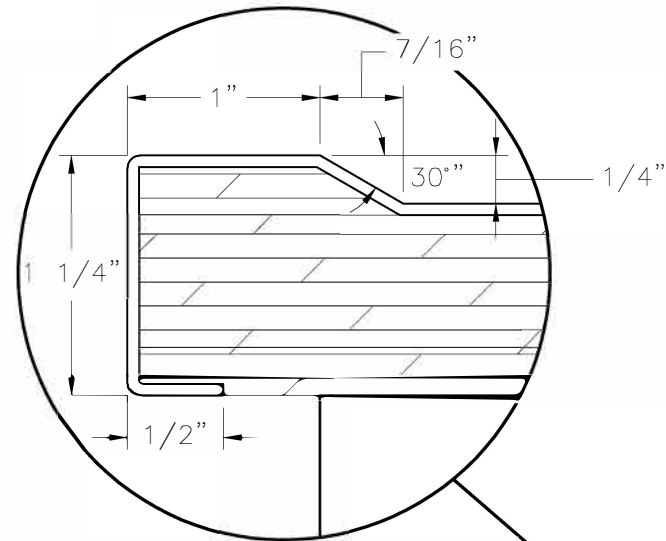

ENLARGED MARINE EDGE DETAIL

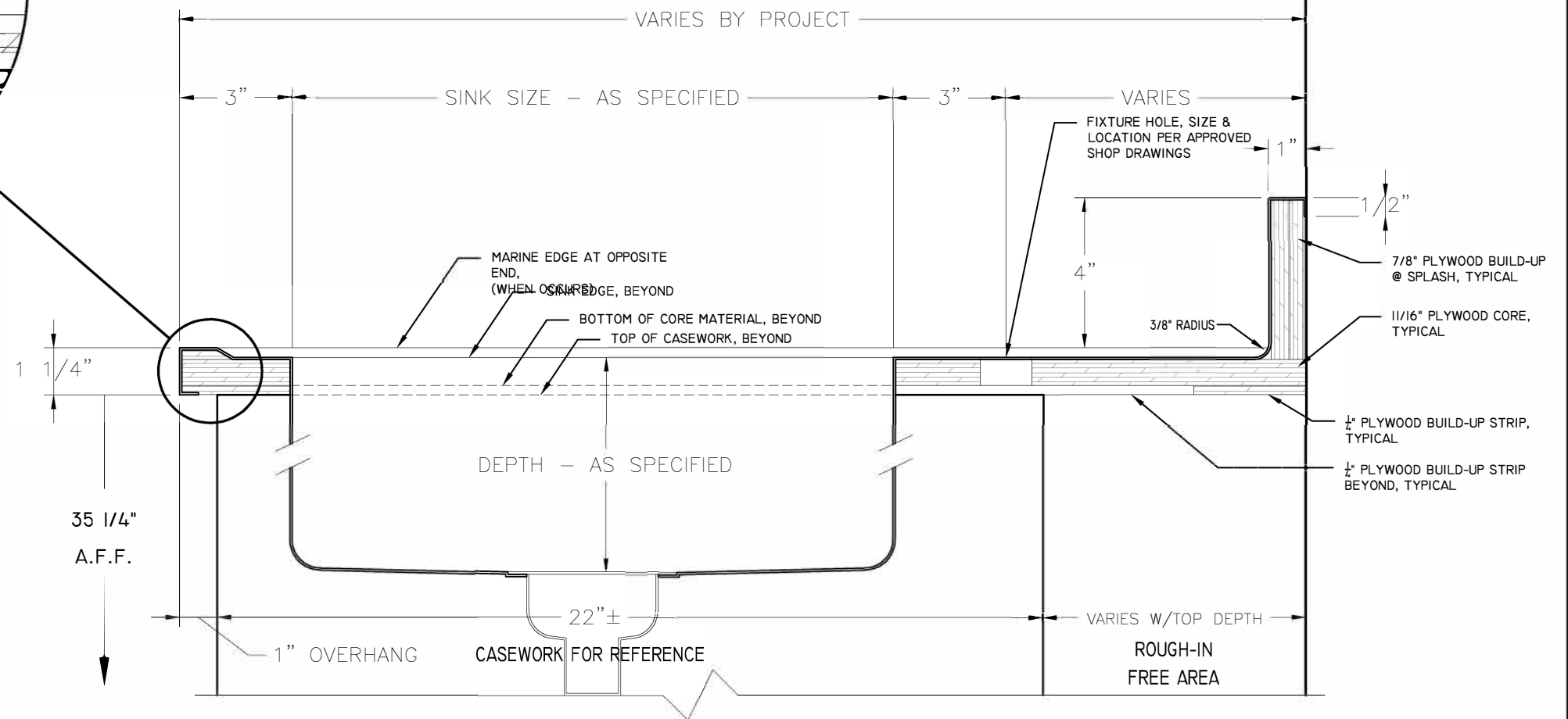

1 TYPICAL PERIMETER STAINLESS STEEL COUNTER TOP WITH MARINE EDGE, PLYWOOD CORE, AND SINK

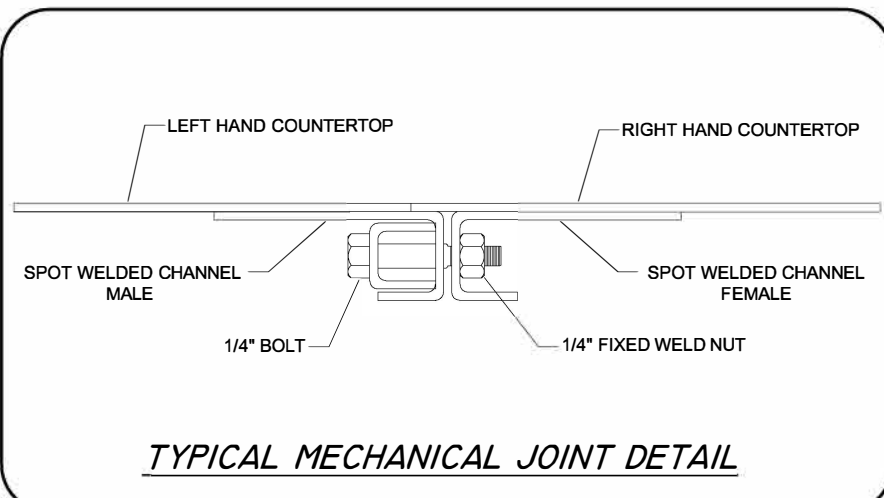

TYPICAL MECHANICAL JOINT DETAIL

NOTES:

REVISIONS		
No	DATE	DESCRIPTION
1	10/06/20	ADDED SHEETS 07 & 08
2	12/30/20	REORDERED/HAT CHANNEL ADJUSTMENT

PROJECT / TITLE	
<b>TYPICAL DETAIL PERIMETER COUNTERTOP STANDARD DETAIL</b>	
DRAWN BY: CADR	DATE: 07/08/16
SCALE: 3"=1'-0"	DWG: 06

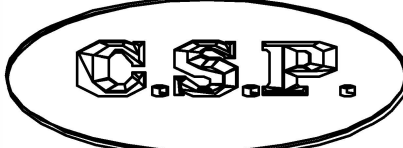

CUSTOM STAINLESS PRODUCTS INC.  
24 VULCAN STREET  
TORONTO, ON M9W 1L2  
TEL: (416) 240 0669  
FAX: (416) 240 8672  
RPRUKNER@CUSTOMSTAINLESSPRODUCTS.COM

CSP PROJECT NUMBER:



**COUNTER TOP CONSTRUCTION**

- 16 GA. ST/STL
- TYPE 304 3/ #4 FINISH
- 11/16" PARTICLE BOARD CORE WITH 1/4" BUILD-UP STRIPS AS REQUIRED

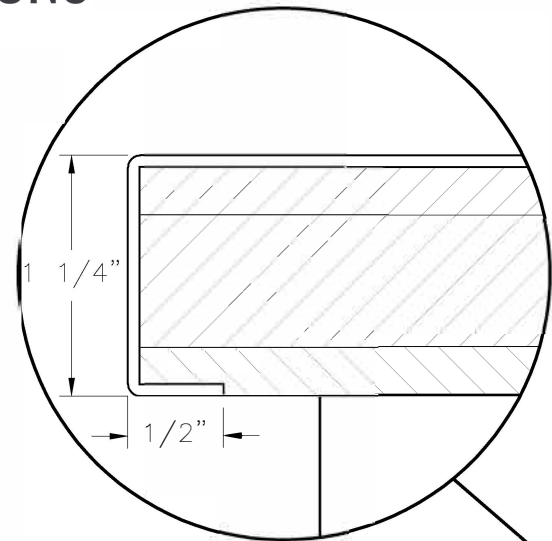

ENLARGED FRONT EDGE DETAIL

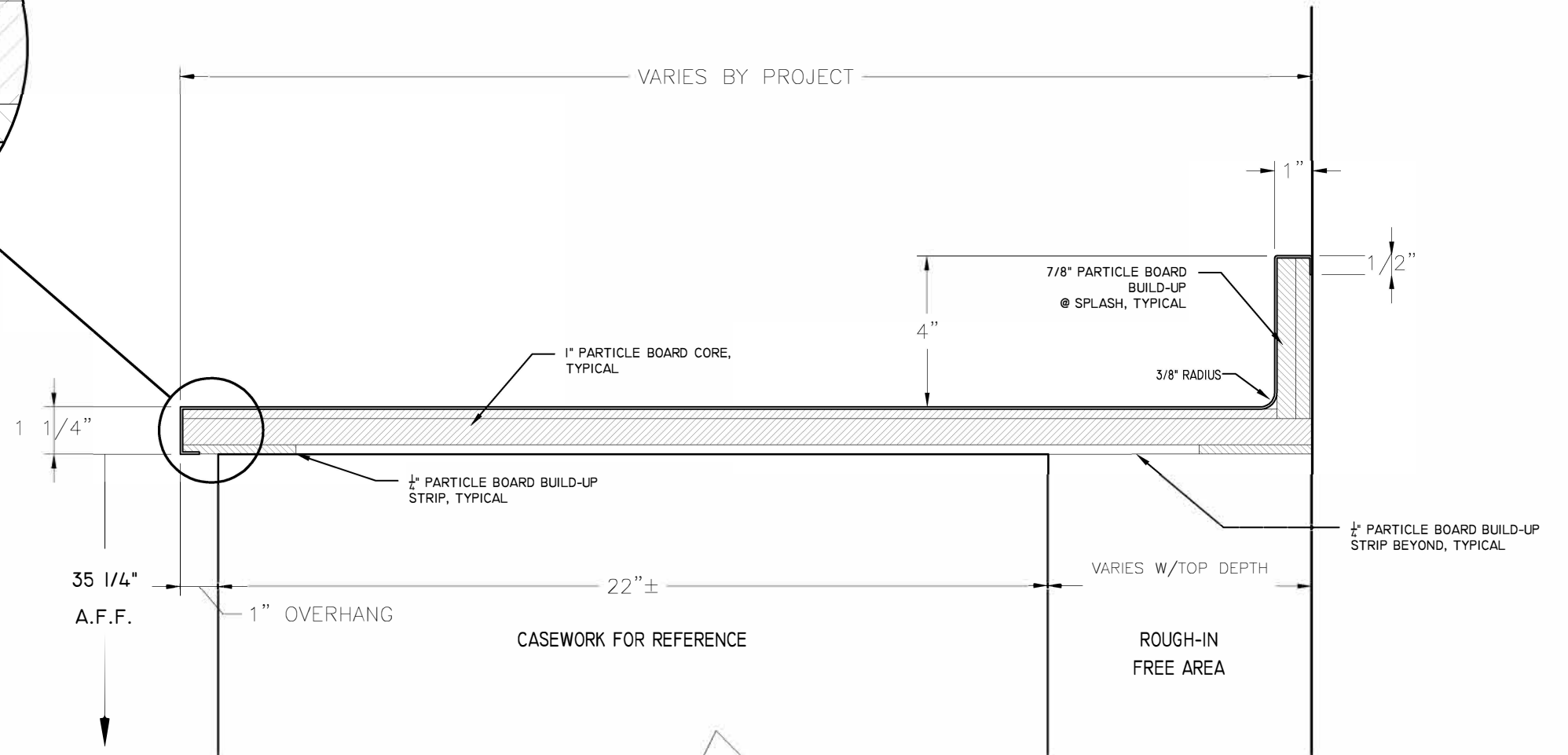

1 TYPICAL PERIMETER STAINLESS STEEL COUNTER TOP WITH PARTICLE BOARD CORE

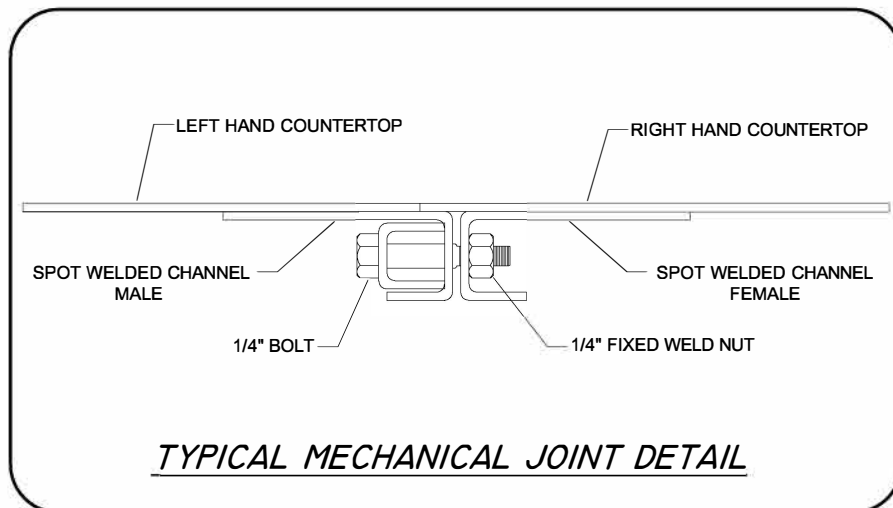

TYPICAL MECHANICAL JOINT DETAIL

NOTES:

REVISIONS		
No	DATE	DESCRIPTION
1	10/06/20	ADDED SHEETS 07 & 08
2	12/30/20	REORDERED/HAT CHANNEL ADJUSTMENT

PROJECT / TITLE  
**TYPICAL DETAIL PERIMETER COUNTERTOP STANDARD DETAIL**

DRAWN BY: CADR      DATE: 07/08/16

SCALE: 3"=1'-0"      DWG: 07

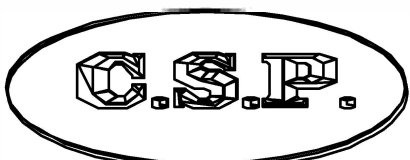

CUSTOM STAINLESS PRODUCTS INC.  
 24 VULCAN STREET  
 TORONTO, ON M9W 1L2  
 TEL: (416) 240 0669  
 FAX: (416) 240 8672  
 RPRUKNER@CUSTOMSTAINLESSPRODUCTS.COM

CSP PROJECT NUMBER:

**COUNTER TOP CONSTRUCTION**

- 16 GA. ST/STL
- TYPE 304 3/ #4 FINISH
- 11/16" PARTICLE BOARD CORE WITH 1/4" BUILD-UP STRIPS AS REQUIRED

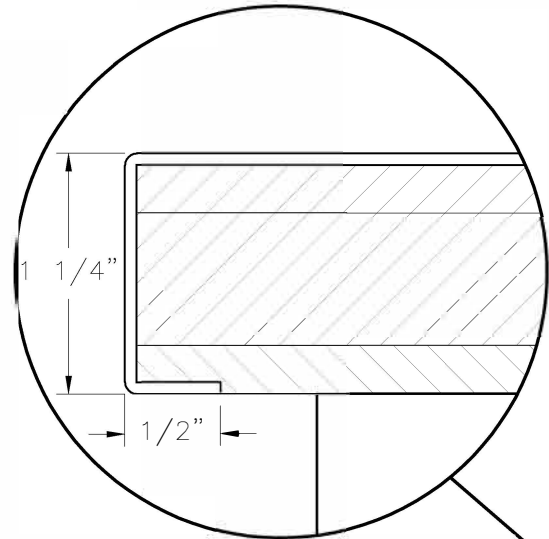

ENLARGED FRONT EDGE DETAIL

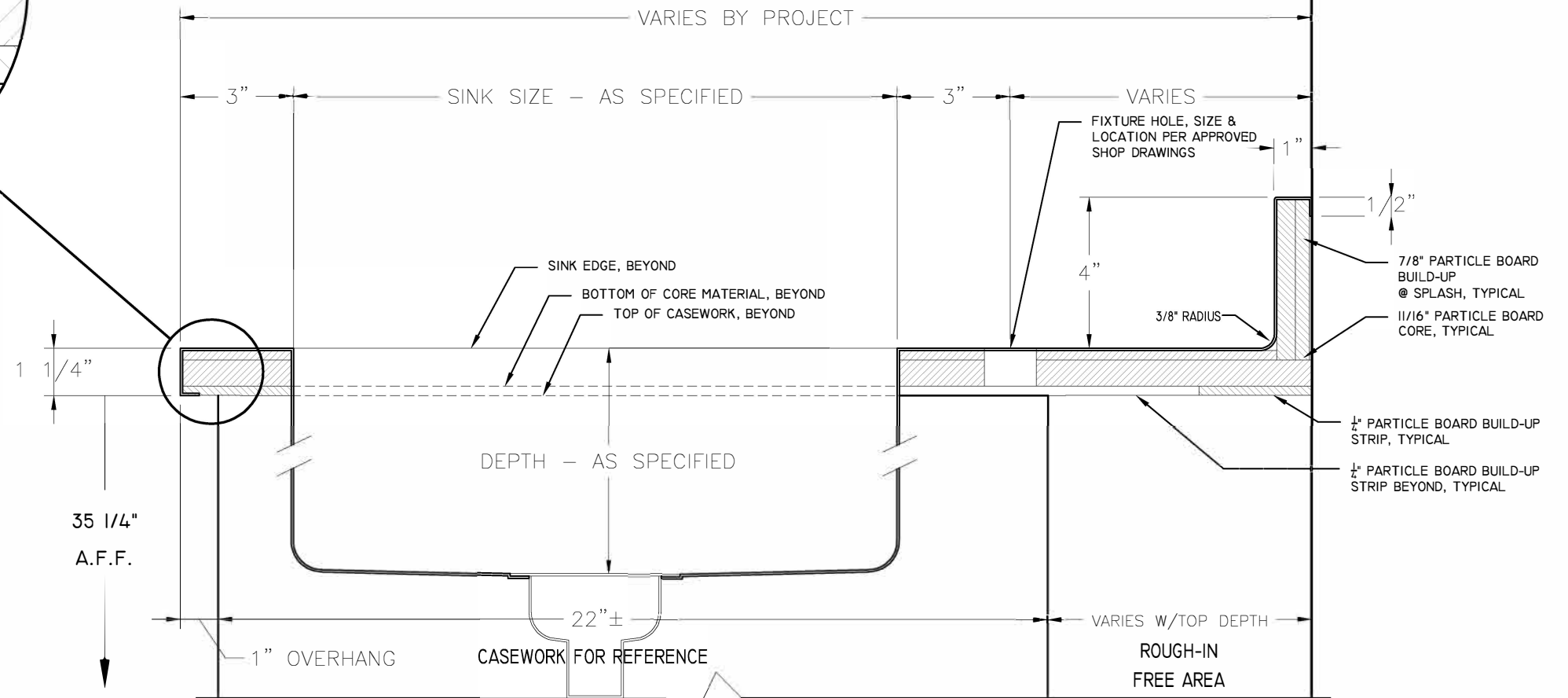

1 TYPICAL PERIMETER STAINLESS STEEL COUNTER TOP WITH PARTICLE BOARD CORE AND SINK

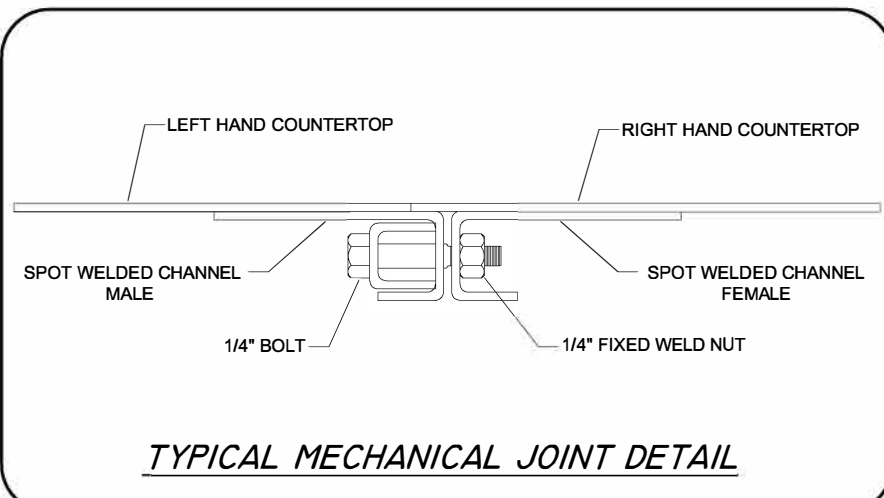

TYPICAL MECHANICAL JOINT DETAIL

NOTES:

REVISIONS		
No	DATE	DESCRIPTION
1	10/06/20	ADDED SHEETS 07 & 08
2	12/30/20	REORDERED/HAT CHANNEL ADJUSTMENT

PROJECT / TITLE  
**TYPICAL DETAIL PERIMETER COUNTERTOP STANDARD DETAIL**

DRAWN BY: CADR DATE: 07/08/16

SCALE: 3"=1'-0" DWG: 08

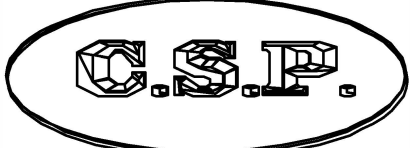

CUSTOM STAINLESS PRODUCTS INC.  
24 VULCAN STREET  
TORONTO, ON M9W 1L2  
TEL: (416) 240 0669  
FAX: (416) 240 8672  
RPRUKNER@CUSTOMSTAINLESSPRODUCTS.COM

CSP PROJECT NUMBER:



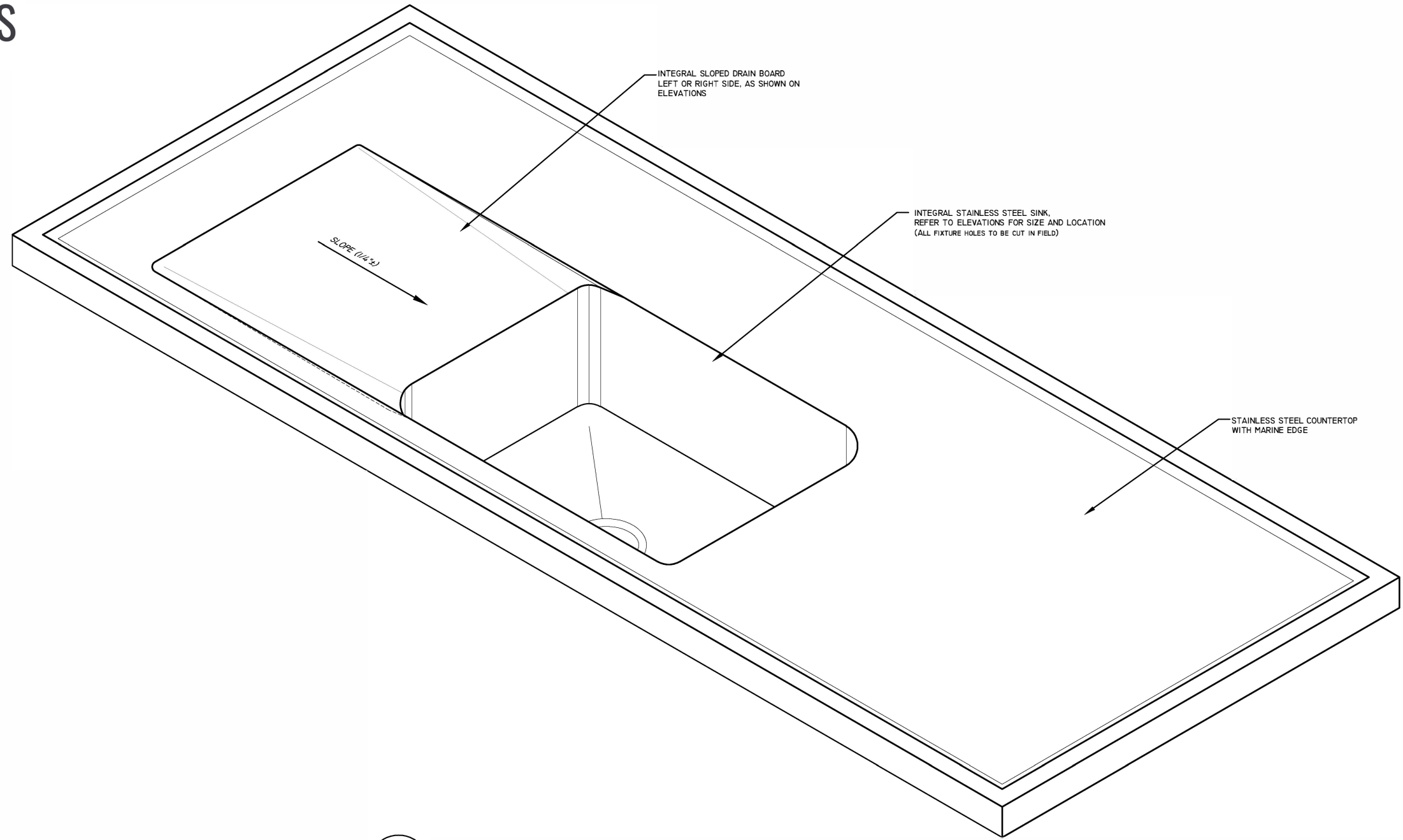

1 TYPICAL DRAIN BOARD @ STAINLESS STEEL COUNTER TOP  
WIDTH TO MATCH SINK, PITCH TO SINK W/OVERALL SLOPE OF 1/4"±

NOTES:

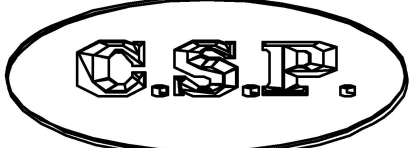

CUSTOM STAINLESS PRODUCTS INC.  
24 VULCAN STREET  
TORONTO, ON M9W 1L2  
TEL: (416) 240 0669  
FAX: (416) 240 8672  
RPRUKNER@CUSTOMSTAINLESSPRODUCTS.COM

CSP PROJECT NUMBER:

REVISIONS		
No	DATE	DESCRIPTION
1	10/06/20	ADDED SHEETS 07 & 08
2	12/30/20	REORDERED/HAT CHANNEL ADJUSTMENT

PROJECT / TITLE	
TYPICAL DRAINBOARD DETAIL	
DRAWN BY: CADR	DATE: 12/30/20
SCALE: AS SHOWN	DWG: 09

**TOP SUPPORT CONSTRUCTION**

- 16 GA. ST/STL
- TYPE 304 3/ #4 FINISH
- FULLY WELDED ASSEMBLY
- ALL WELDS GROUND AND POLISHED FOR A UNIFORM FINISH
- SS FINISH CAPS PROVIDED TO CONCEAL WALL ATTACHMENT HOLES
- QUANTITY: —

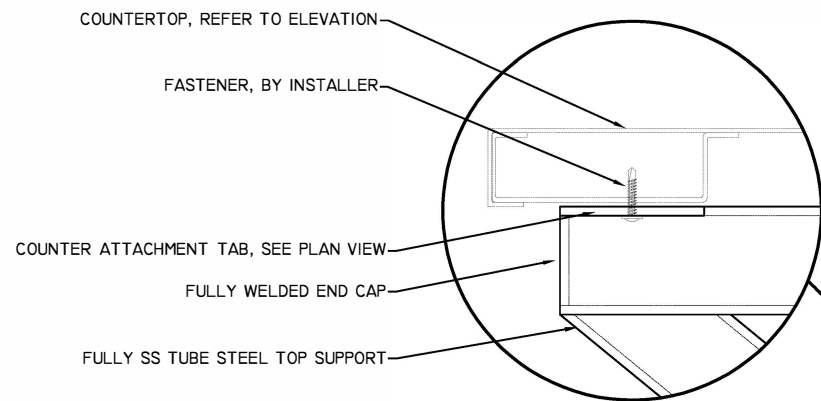

**ENLARGED COUNTERTOP CONNECTION VIEW**

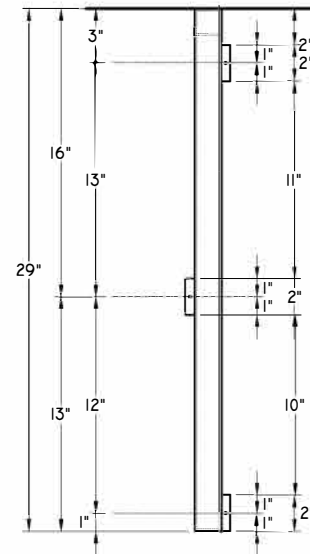

**PLAN VIEW**

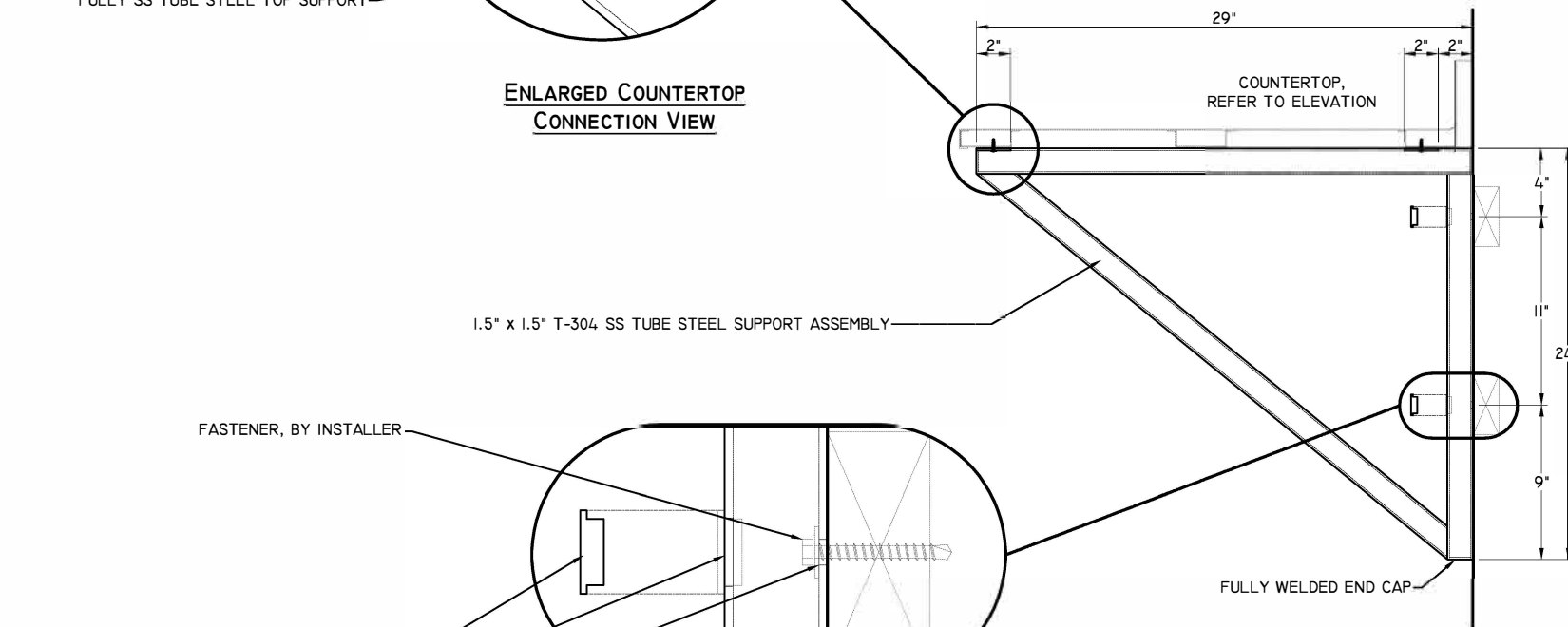

**RIGHT SIDE VIEW**

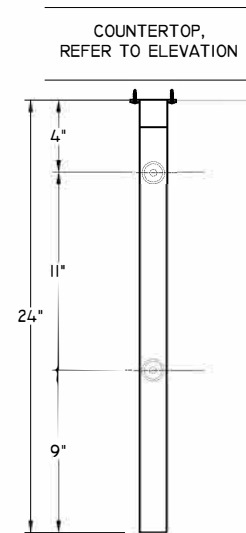

**ELEVATION VIEW**

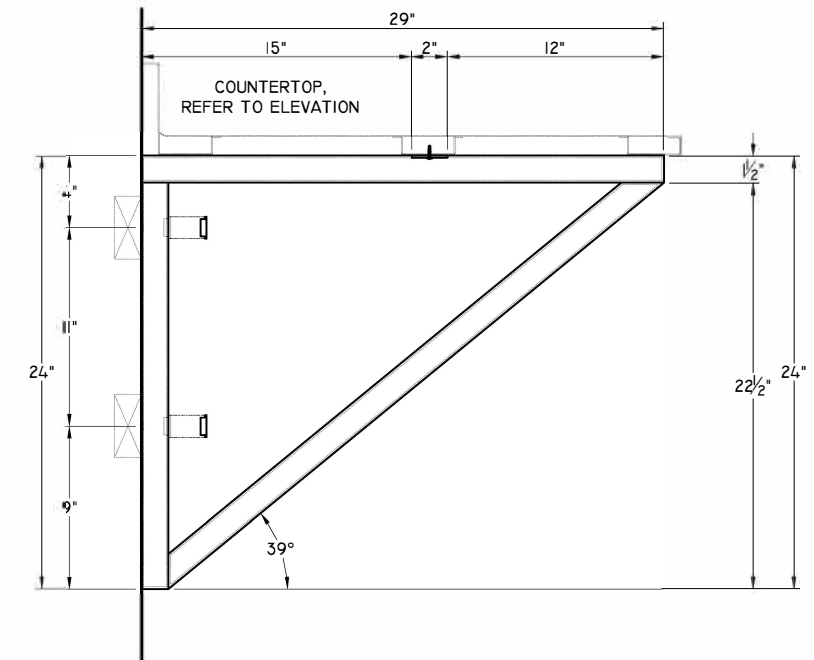

**LEFT SIDE VIEW**

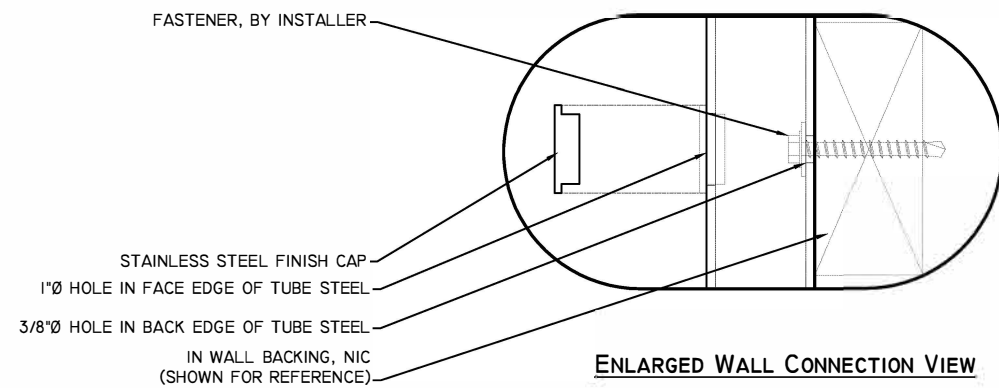

**ENLARGED WALL CONNECTION VIEW**

NOTES:

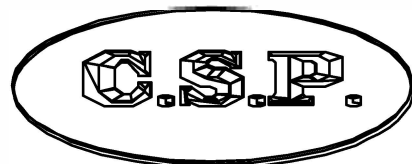

CUSTOM STAINLESS PRODUCTS INC.  
 24 VULCAN STREET  
 TORONTO, ON M9W 1L2  
 TEL: (416) 240 0669  
 FAX: (416) 240 8672  
[RPRUKNER@CUSTOMSTAINLESSPRODUCTS.COM](mailto:RPRUKNER@CUSTOMSTAINLESSPRODUCTS.COM)

CSP PROJECT NUMBER:

REVISIONS		
No	DATE	DESCRIPTION
1	10/06/20	ADDED SHEETS 07 & 08
2	12/30/20	REORDERED/HAT CHANNEL ADJUSTMENT

PROJECT / TITLE	
<b>TYPICAL DETAIL PERIMETER COUNTERTOP KNEEBRACE DETAIL</b>	
DRAWN BY: CADR	DATE: 12/30/20
SCALE: AS SHOWN	DWG: 10